

Solar Oven



Objective

Students will be able to describe the energy transformation involved when using a solar oven.

Materials

- 1 Small pizza box
- Plastic wrap
- Aluminum foil
- 1 Wooden skewer (12"-18")
- Marker
- Scissors
- Ruler
- Masking tape
- 1 Paper plate*
- Black construction paper
- Oven thermometer
- Food to cook

***NOTE:** Dark-colored paper plates work best, if available.

General Directions to Build a Solar Oven

1. On the top of the pizza box, use your marker to draw a square with edges spaced 1" from all sides of the box.
2. Use scissors to cut along the sides and front edge of the lid, leaving the fourth side along the box's hinge uncut, as shown in diagram 1.
3. Tape aluminum foil to the inside surface of the new flap you just cut, shiny side visible. This is to reflect sunlight into the box. Smooth out any wrinkles that might occur.
4. Tape plastic wrap to the original box flap so that it covers the hole you cut into the flap. Seal all four of the edges with tape.
5. Tape black construction paper to the bottom inside of the box. This will help absorb the incoming sunlight. See diagram 2 to make sure you have assembled steps 3-5 correctly.
6. Cover any air leaks around the box edges with tape, making sure that the box can still be opened to place food inside or remove it later.
7. Go outside in the sunlight and place the solar oven on a level flat surface.
8. Place food items on a paper plate and place it inside the oven. Put the oven thermometer inside the oven where you will be able to see it without moving the oven.
9. Tape one end of a wooden skewer to the reflector lid, attach the other end to the box to adjust reflector.
10. Let the food cook and periodically check the reflector angle to make sure sunlight is getting inside the oven.

Diagram 1

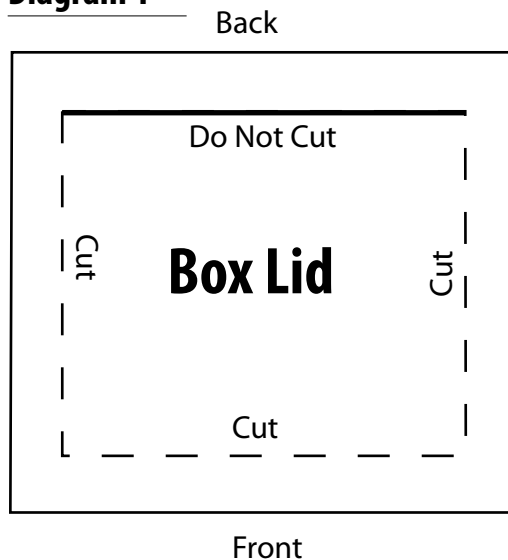

Diagram 2

